

 RISK OF ELECTRICAL SHOCK! DISCONNECT POWER BEFORE INSTALLATION OR SERVICING.

 TO BE INSTALLED BY A QUALIFIED ELECTRICIAN IN ACCORDANCE TO LOCAL & NATIONAL ELECTRIC CODES.

 FAILURE TO COMPLY TO INSTRUCTIONS & FORMENTIONED WARNINGS COULD VOID PRODUCT WARRANTY.

 DO NOT CONSTRUCT ROW ON FLOOR & LIFT TO CEILING.

 CEILING TO BE PROPERLY REINFORCED TO SUPPORT WEIGHT OF THE FIXTURE.

 REFERENCE SHOP DRAWINGS FOR CRITICAL MOUNTING DIMENSIONS.

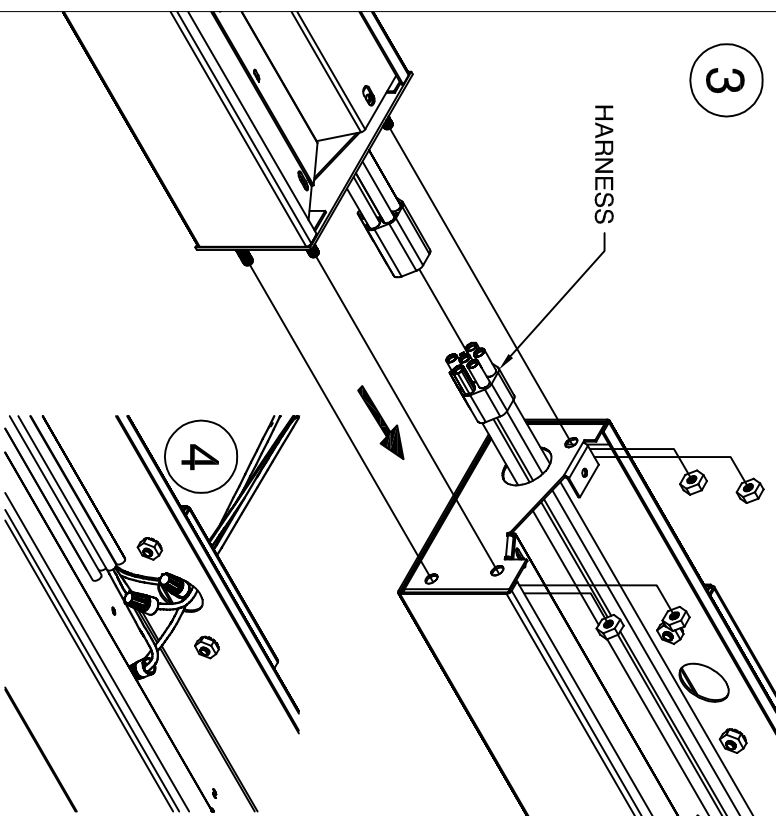
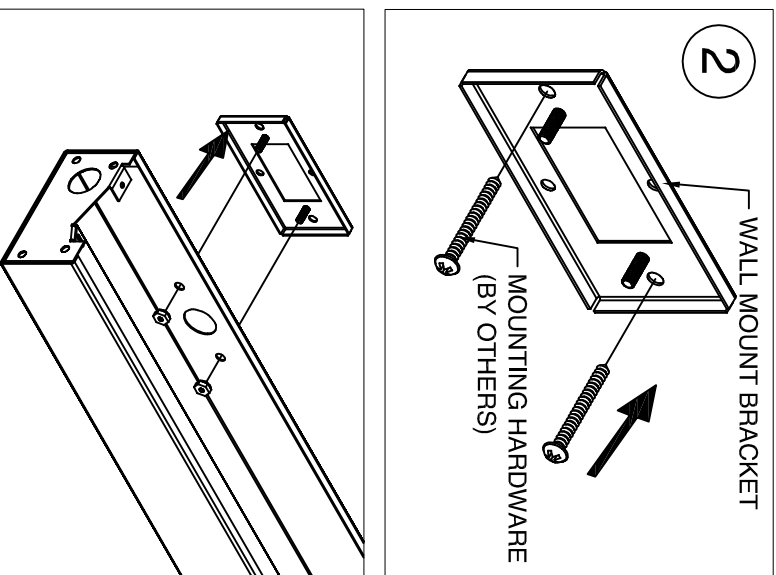
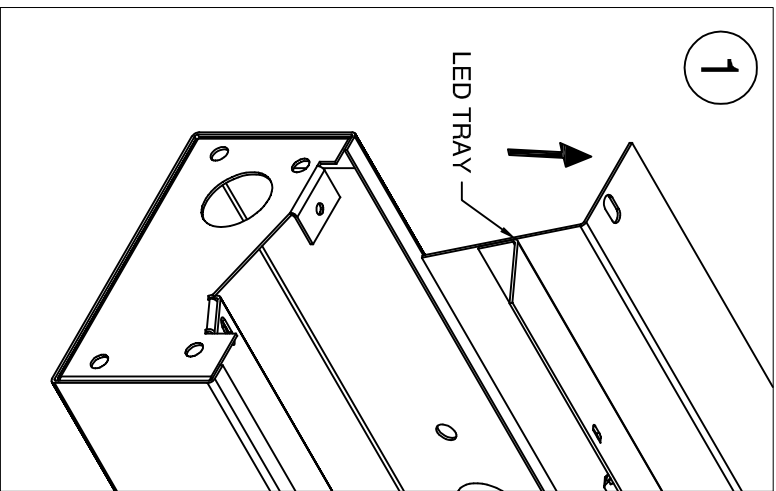

1. LOCATE MOUNTING POINTS. REFER TO JOB DRAWINGS FOR SPECIFIC DETAILS. REMOVE LED TRAY ASSEMBLY AND OR LENS FROM FIXTURE TO BE INSTALLED. **DO NOT MIX LENSES AND REFLECTORS.**

2. MOUNT FIXTURE. USE APPROPRIATE HARDWARE (BY OTHERS) TO SECURE FIXTURE TO SURFACE.

3. MOUNT NEXT FIXTURE. REMOVE LENSES AND REFLECTORS, FROM FIXTURES. **DO NOT MIX LENSES AND REFLECTORS.** CONNECT HARNESS ENDS AND JOIN TO ALREADY HUNG FIXTURE USING SUPPLIED HARDWARE. CONTINUE HANGING AND JOINING FIXTURES UNTIL ROW IS COMPLETE.

4. FEED POWER FEED CORD THROUGH HOLE IN FIXTURE. USE APPROPRIATE STRAIN RELIEF TO SECURE WIRES IN FIXTURE AS REQUIRED BY LOCAL ELECTRICAL CODES. CUT END FROM HARNESS AND CONNECT POWER FEED CONDUCTORS TO APPROPRIATE WIRES OF WIRE HARNESS. STANDARD WIRING DIAGRAM SHOWN, REFER TO JOB DRAWINGS FOR JOB SPECIFIC WIRING

5. REINSTALL COMPONENTS AFTER ALL WIRING CONNECTIONS ARE MADE. INSTALLATION IS COMPLETE

MUST BE INSTALLED BY A QUALIFIED ELECTRICIAN. DISCONNECT POWER DURING INSTALLATION/SERVICING. ROW CONFIGURATION IS JOB SPECIFIC. CONSULT SHOP DRAWINGS BEFORE CONSTRUCTING ROWS. STANDARD OPTIONS/SIZES SHOWN. OTHER OPTIONS AVAILABLE WITH SIMILAIR INSTALLATION. BE SURE TO UNDERSTAND ALL PROCEDURES PRIOR TO INSTALLATION. IMPORTANT: THE NATIONAL ELECTRIC CODE REQUIRES THAT ANY FIXTURE IN EXCESS OF 50 POUNDS MUST BE INDEPENDENTLY SUPPORTED OF THE OUTLET BOX. DAY-O-LITE IS NOT RESPONSIBLE FOR INADEQUATE REINFORCEMENT OF STRUCTURAL SUPPORT SYSTEMS. DAY-O-LITE RESERVES THE RIGHT TO MAKE ANY MECHANICAL OR MATERIAL CHANGES TO THE FIXTURES WHICH DO NOT AFFECT THE APPEARANCE OR PERFORMANCE. THIS PRINT IS THE PROPERTY OF DAY-O-LITE AND THE INFORMATION IT CONTAINS MAY NOT BE USED WITHOUT WRITTEN CONSENT OF DAY-O-LITE.

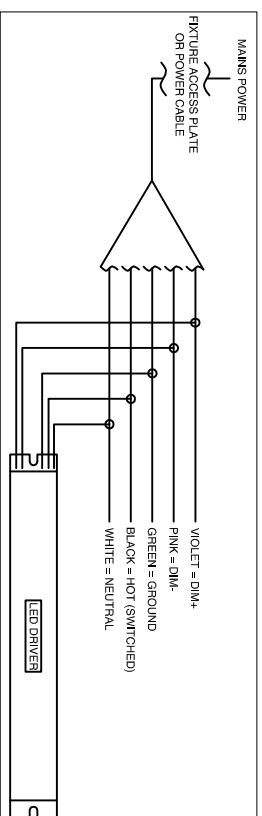

MODEL NO.:
ELTL3 WM D/DI.

CONTACT INFORMATION:
128 Chestnut Street, Warwick, RI 02888
Tel. (401) 467-8232 | Fax. (401) 941-2960
E-mail: sales@dayville.com
WWW: <http://www.dayville.com>

PAGE:
SHEET 1 OF 1

ISSUED ON:
8/25/22

PART NUMBER:
970147A0

 **DAY-O-LITE**
Lighting Without Limits