

# TSLL INSTALLTION



LEDS ARE EASILY DAMAGED,  
AVOID CONTACT WHEN  
INSTALLING AND SERVICING.



RISK OF ELECTRICAL SHOCK.  
DISCONNECT POWER  
BEFORE INSTALLATION OR  
SERVICING.



TO BE INSTALLED BY A  
QUALIFIED ELECTRICIAN IN  
ACCORDANCE TO LOCAL &  
NATIONAL ELECTRIC CODES.

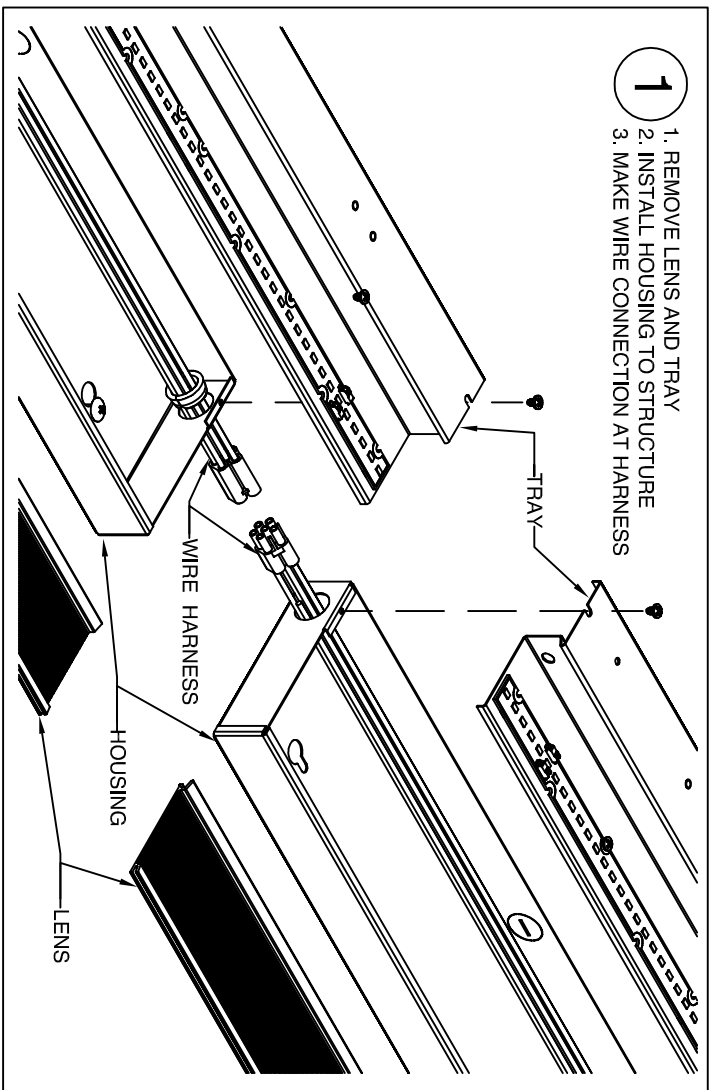

1. REMOVE LENS AND TRAY
2. INSTALL HOUSING TO STRUCTURE
3. MAKE WIRE CONNECTION AT HARNESS

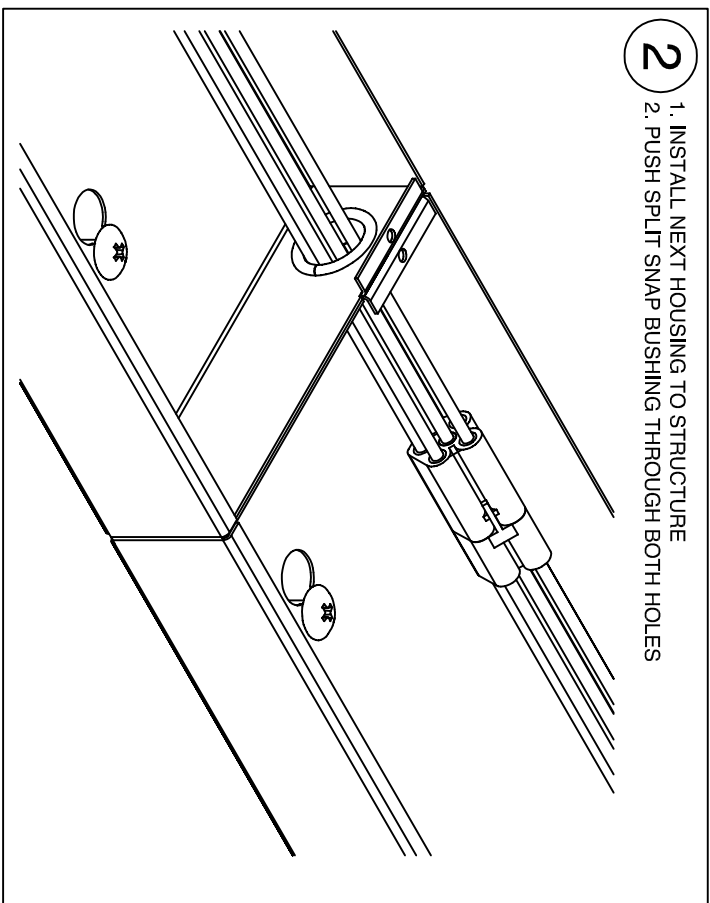

2. 1. INSTALL NEXT HOUSING TO STRUCTURE
2. 2. PUSH SPLIT SNAP BUSHING THROUGH BOTH HOLES

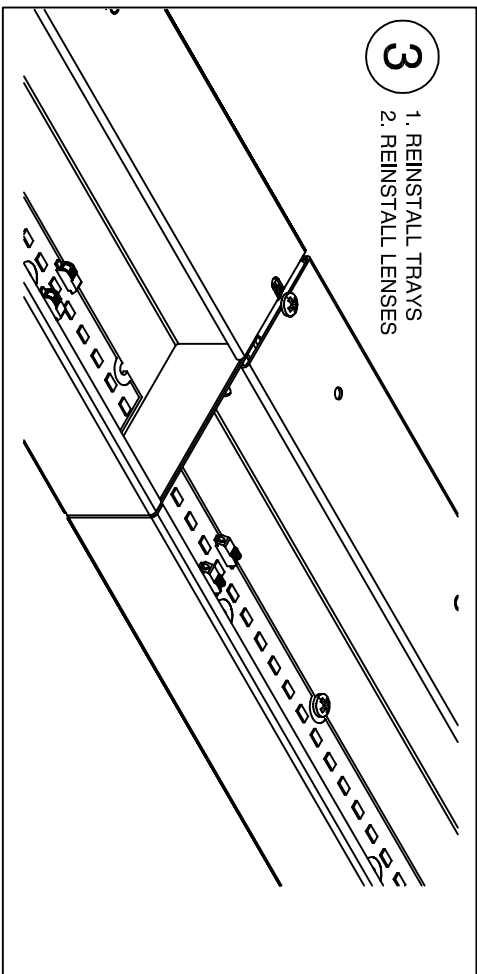

3. 1. REINSTALL TRAYS
2. REINSTALL LENSES

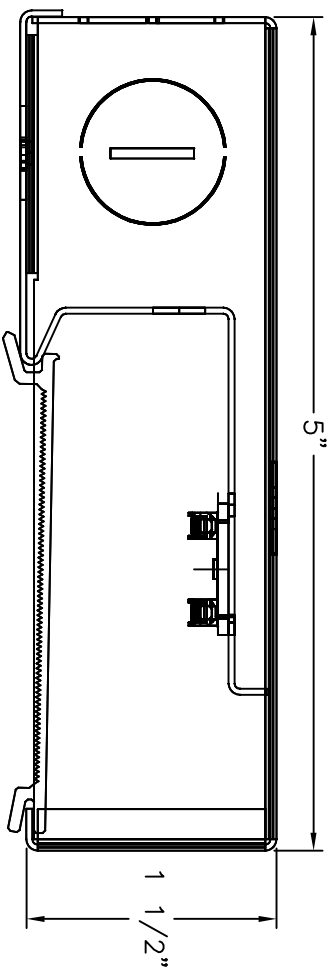

MUST BE INSTALLED BY A QUALIFIED ELECTRICIAN. DISCONNECT POWER DURING INSTALLATION/SERVICING. ROW CONFIGURATION IS JOB SPECIFIC. CONSULT SHOP DRAWINGS BEFORE CONSTRUCTING ROWS. STANDARD OPTIONS/SIZES SHOWN. OTHER OPTIONS AVAILABLE WITH SIMILAIR INSTALLATION. BE SURE TO UNDERSTAND ALL PROCEDURES PRIOR TO INSTALLATION. IMPORTANT: THE NATIONAL ELECTRIC CODE REQUIRES THAT ANY FIXTURE IN EXCESS OF 50 POUNDS MUST BE INDEPENDENTLY SUPPORTED OF THE OUTLET BOX. DAY-O-LITE IS NOT RESPONSIBLE FOR INADEQUATE REINFORCEMENT OF STRUCTURAL SUPPORT SYSTEMS. DAY-O-LITE RESERVES THE RIGHT TO MAKE ANY MECHANICAL OR MATERIAL CHANGES TO THE FIXTURES WHICH DO NOT AFFECT THE APPEARANCE OR PERFORMANCE. THIS PRINT IS THE PROPERTY OF DAY-O-LITE AND THE INFORMATION IT CONTAINS MAY NOT BE USED WITHOUT WRITTEN CONSENT OF DAY-O-LITE.

MODEL NO.: TSLL	PAGE: SHEET 1 OF 1	ISSUED ON: 9/7/19
CONTACT INFORMATION: 128 Chestnut Street, Warwick, RI 02888 Tel. (401) 467-8232   Fax. (401) 941-2960 E-mail: sales@dayville.com WWW: http://www.dayville.com		
 <b>DAY-O-LITE</b> Lighting Without Limits		