

# TRPL FIXTURE INSTALLATION



**RISK OF ELECTRICAL SHOCK. DISCONNECT POWER BEFORE INSTALLATION OR SERVICING.**



**TO BE INSTALLED BY A QUALIFIED ELECTRICIAN IN ACCORDANCE TO LOCAL & NATIONAL ELECTRIC CODES.**



**FAILURE TO COMPLY TO INSTRUCTIONS & FORMENTIONED WARNINGS COULD VOID PRODUCT WARRANTY**

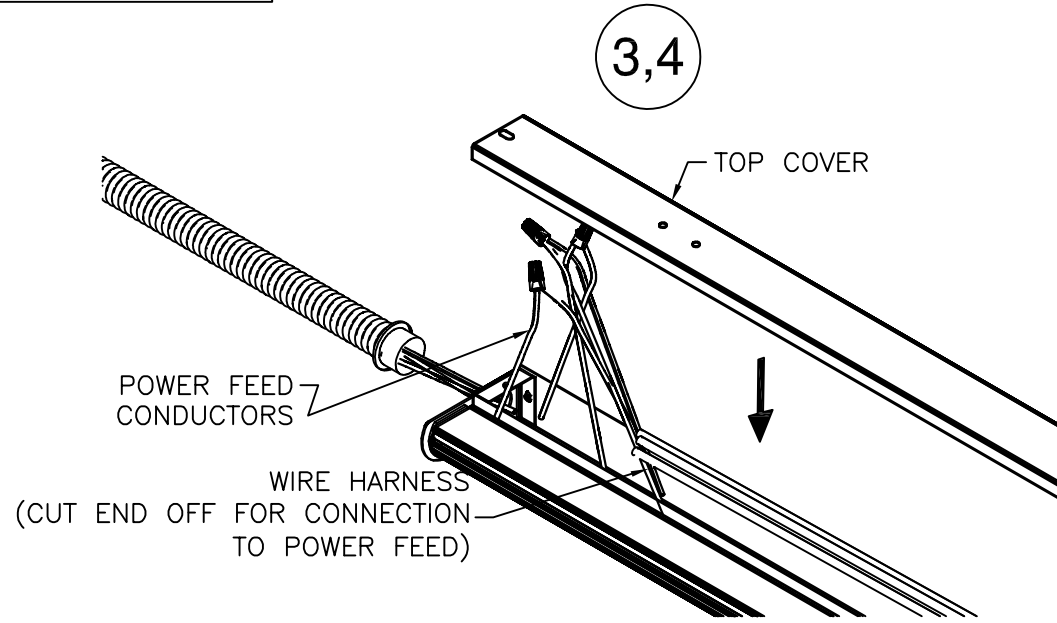
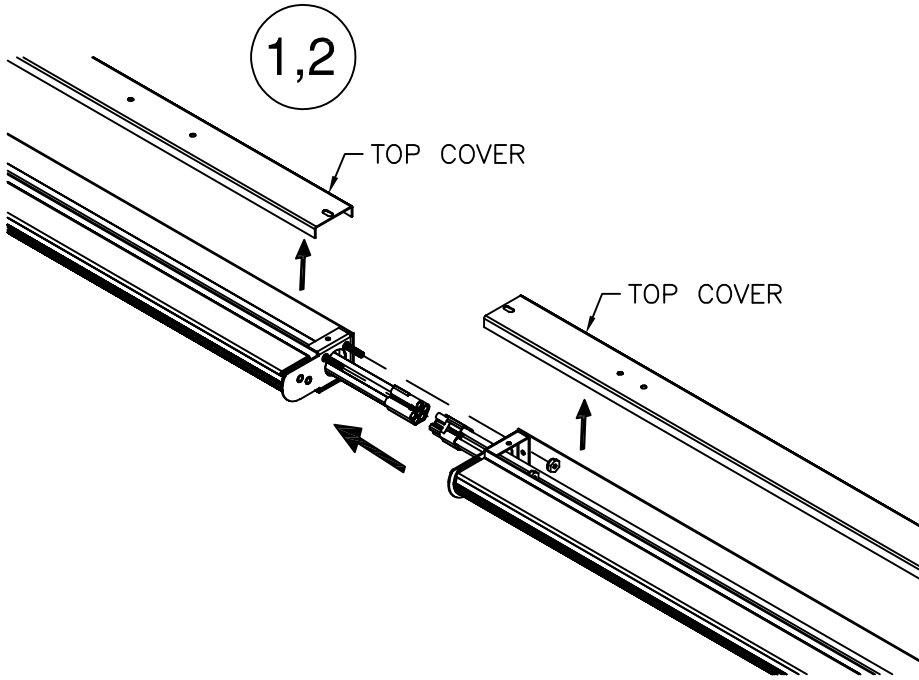

1. PLACE FIXTURE AT MOUNTING LOCATION.

2. PLACE NEXT FIXTURE TO BE INSTALLED. REMOVE TOP COVER FROM FIXTURES. CONNECT WIRE HARNESSES AND JOIN FIXTURES USING SUPPLIED HARDWARE . CONTINUE INSTALLING UNTIL ROW IS COMPLETE.

3. FEED POWER FEED CORD THROUGH HOLE IN END OF FIXTURE. USE APPROPRIATE STRAIN RELIEF TO SECURE CORD IN FIXTURE AS REQUIRED BY LOCAL ELECTRICAL CODES. CUT END FROM HARNESS AND CONNECT POWER FEED CONDUCTORS TO APPROPRIATE WIRES OF WIRE HARNESS. STANDARD WIRING DIAGRAM SHOWN, REFER TO JOB DRAWINGS FOR JOB SPECIFIC WIRING

4. REINSTALL TOP TRAY AFTER ALL WIRING CONNECTIONS ARE MADE. RE-INSTALL TOP TRAYS IN ALL FIXTURES. INSTALLATION IS COMPLETE

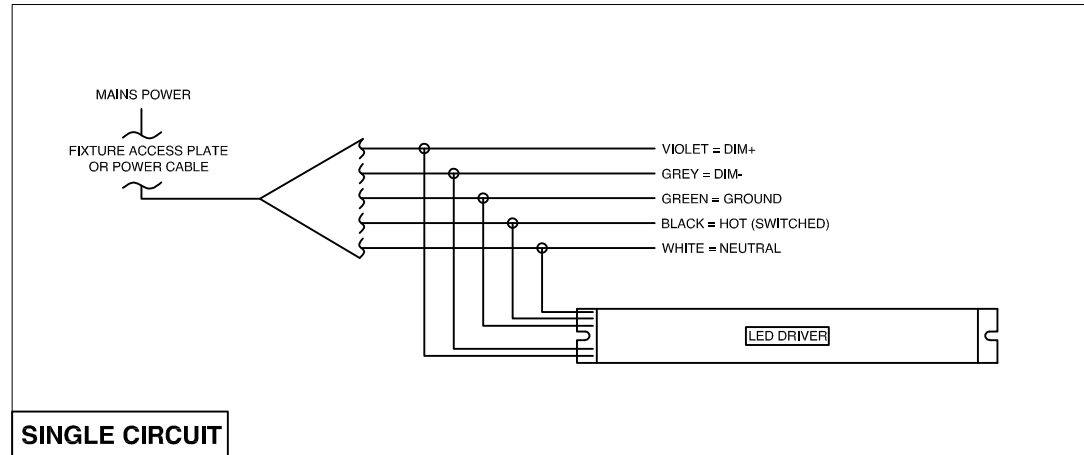

**MUST BE INSTALLED BY A QUALIFIED ELECTRICIAN. DISCONNECT POWER DURING INSTALLATION/SERVICING. ROW CONFIGURATION IS JOB SPECIFIC, CONSULT SHOP DRAWINGS BEFORE CONSTRUCTING ROWS. STANDARD OPTIONS/SIZES SHOWN, OTHER OPTIONS AVAILABLE WITH SIMILAIR INSTALLATION. BE SURE TO UNDERSTAND ALL PROCEDURES PRIOR TO INSTALLATION. IMPORTANT: THE NATIONAL ELECTRIC CODE REQUIRES THAT ANY FIXTURE IN EXCESS OF 50 POUNDS MUST BE INDEPENDENTLY SUPPORTED OF THE OUTLET BOX. DAY-O-LITE IS NOT RESPONSIBLE FOR INADEQUATE REINFORCEMENT OF STRUCTURAL SUPPORT SYSTEMS. DAY-O-LITE RESERVES THE RIGHT TO MAKE ANY MECHANICAL OR MATERIAL CHANGES TO THE FIXTURES WHICH DO NOT AFFECT THE APPEARANCE OR PERFORMANCE. THIS PRINT IS THE PROPERTY OF DAY-O-LITE AND THE INFORMATION IT CONTAINS MAY NOT BE USED WITHOUT WRITTEN CONSENT OF DAY-O-LITE.**

MODEL NO.:  
TRPL-  
CONTACT INFORMATION:  
126 Chestnut Street, Warwick, RI 02888  
Tel. (401) 467-8232 | Fax. (401) 941-2960  
E-mail: sales@dayolite.com  
WWW: http://www.dayolite.com

PART NUMBER:  
**970058A0**  
ISSUED ON:  
11/19/2019  
 **DAY-O-LITE**  
Lighting Without Limits